

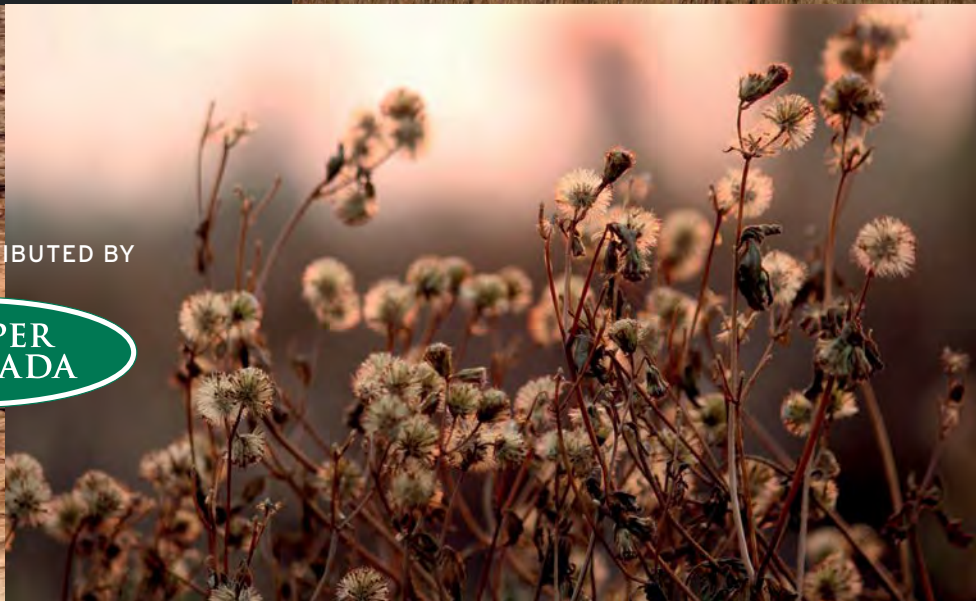

Hotán®

finest acoustic collection - harmony

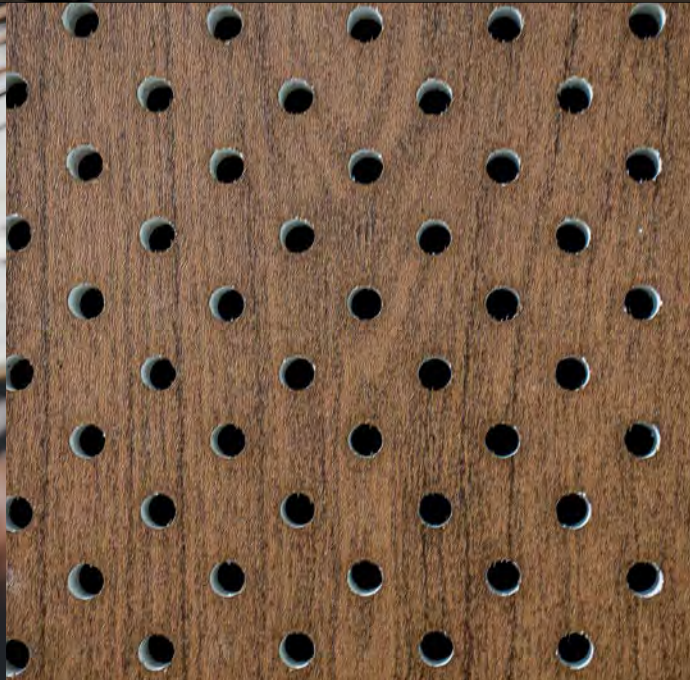

PROUDLY DISTRIBUTED BY



Hotán® finest acoustic panels

Hotán® finest acoustic panels are available in untreated oak, ash, walnut and smoked oak. Other wood species are available on request.

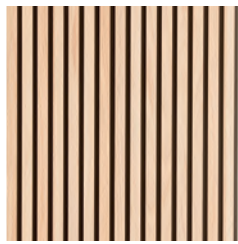

OAK

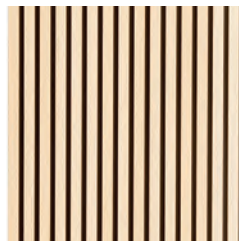

ASH

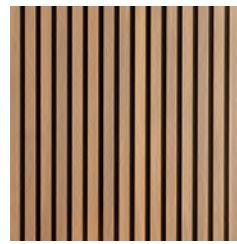

AMERICAN WALNUT

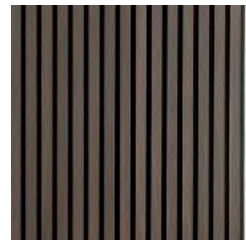

SMOKED OAK

The acoustic panels are delivered in pre-built modules, which makes it simple and easy to mount them in the ceiling or on the wall. If you need to integrate electricity, lighting or ventilation in the panels, we recommend that you get professionals to help you with the adjustments.

Standard size: 2400 x 600 mm and 3000 x 600mm x 20mm

On request: 3600 x 600mm x 20mm

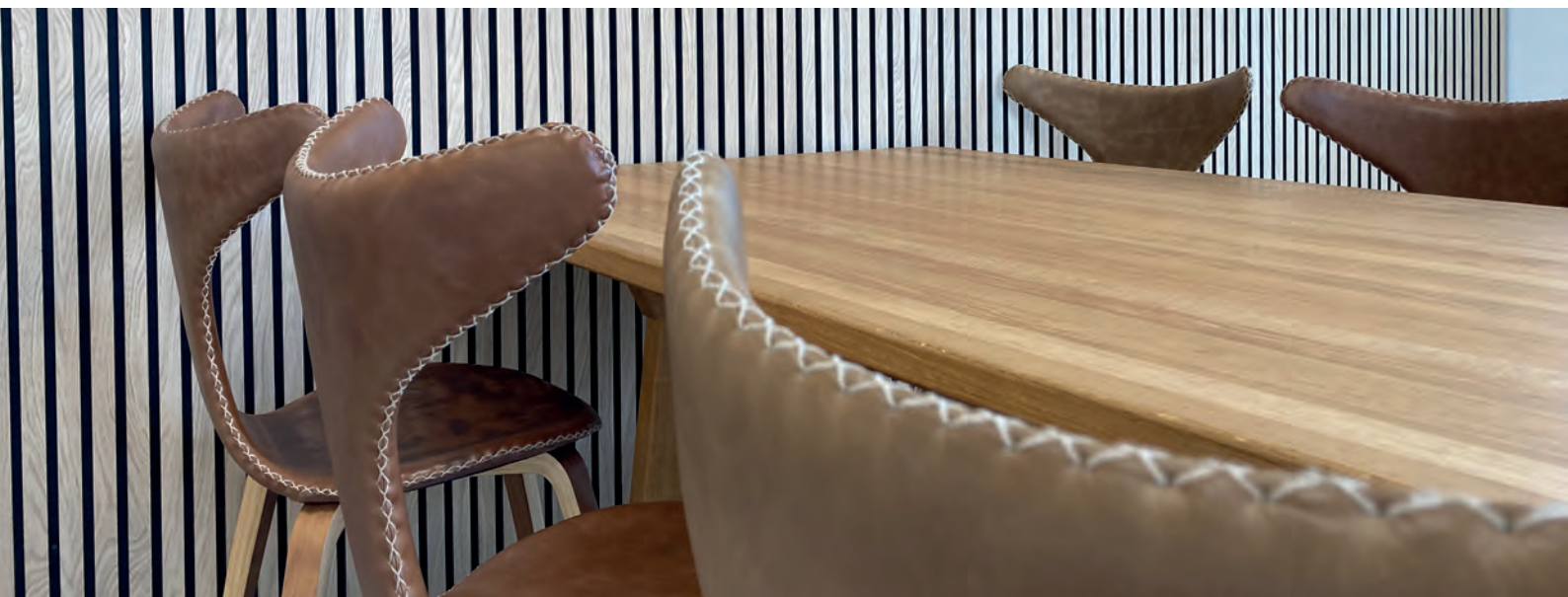



Facts

Hotán® finest acoustic panels consists of a 9 mm black PET Polyester non-woven fabric on which 27x11 mm strips are mounted in through-colored black MDF veneered with real wood veneer. The strips are spaced 13 mm apart.

Info:

Dimensions: 2400x600x20 mm
3000x600x20 mm

Properties of real wood veneer:

Real wood veneer can vary in color, grain structure and appearance from batch to batch.

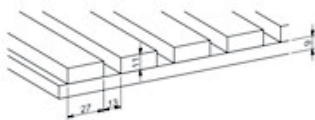

Assembly

Hotán® finest acoustic panels can be used on ceilings as well as walls. It is recommended to mount the panels on 45 mm thick joists with a mutual distance of max. 600 mm. However, the panels can also be mounted directly to the wall. The screws are placed between the strips through the non-woven fabric. For fastening, a minimum of 15 flat head screws should be used per panel.

Screw size: at least Ø3.5x35 mm

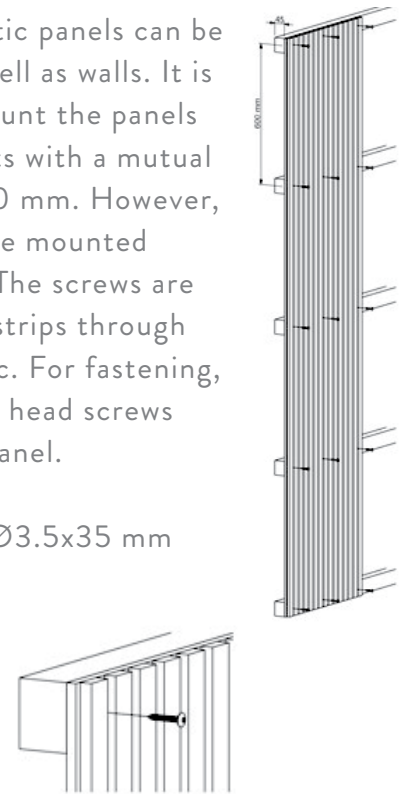

Acoustic improvement

The acoustic panels break the straight surfaces and significantly improve room acoustics. The panels are designed to reduce noise up to 50% in the room they are installed in.

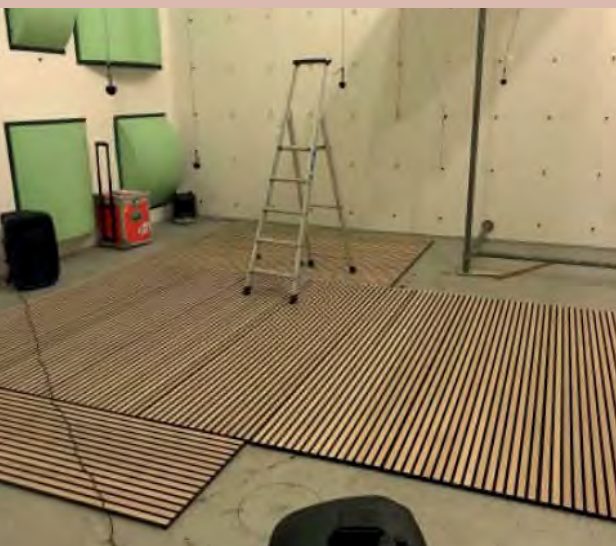
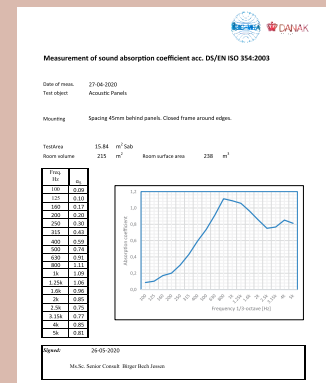

Method

The determination of the sound absorption is based on measurements of the change of reverberation times, measured in a highly reverberant room with and without the test specimens placed in this room. Measurements are made in 1/3-octave levels from 50 Hz to 10 kHz, with a usable range between 100 Hz to 5000 Hz. Results are given in 1/3 and 1/1-octave levels, and frequency weighted single values are calculated.

$$\alpha_s = \frac{55.3 \cdot V}{c \cdot S} \cdot \left(\frac{1}{T_2} - \frac{1}{T_1} \right) - \frac{4V}{S} \cdot (m_2 - m_1)$$

Where

α_s is the absorption coefficient at given frequency band, V is Volume of test room [m³], c is speed of sound [m/s], S is surface area of test room [m²], T1 and T2 is measured reverberation time [sec], T1 with test object, T2 empty room, and m is damping coefficient of air when measuring with and without test object.

The damping coefficient is given as imperial values in standard DS/ISO 9613-1:1993. By aiming for same thermal conditions of air temperature and humidity, the damping coefficients cancel out. If this condition has not been possible an estimated correction may be added, which normally is very small and only relevant for the highest frequencies.



Upper Canada Forest Products
1 866 265 0624 | www.ucfp.com

Edmonton 780 863 3316 sales_edmonton@ucfp.com
Calgary 403 569 8829 sales_calgary@ucfp.com
Kelowna 250 765 2018 sales_kelowna@ucfp.com
Vancouver 604 522 3334 sales_vancouver@ucfp.com
Victoria 778 426 4220 sales_victoria@ucfp.com



FINEST VENEERED PRODUCTS